

Installation
Montage
Montaje
Montaggio
Montage

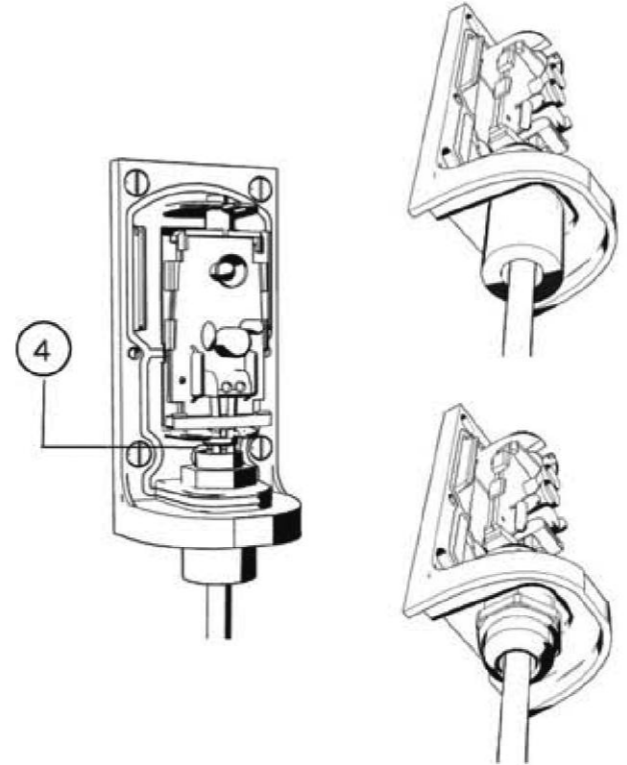

Orientation
Optische Ausrichtung
Orientación
Orientamento
Orientación

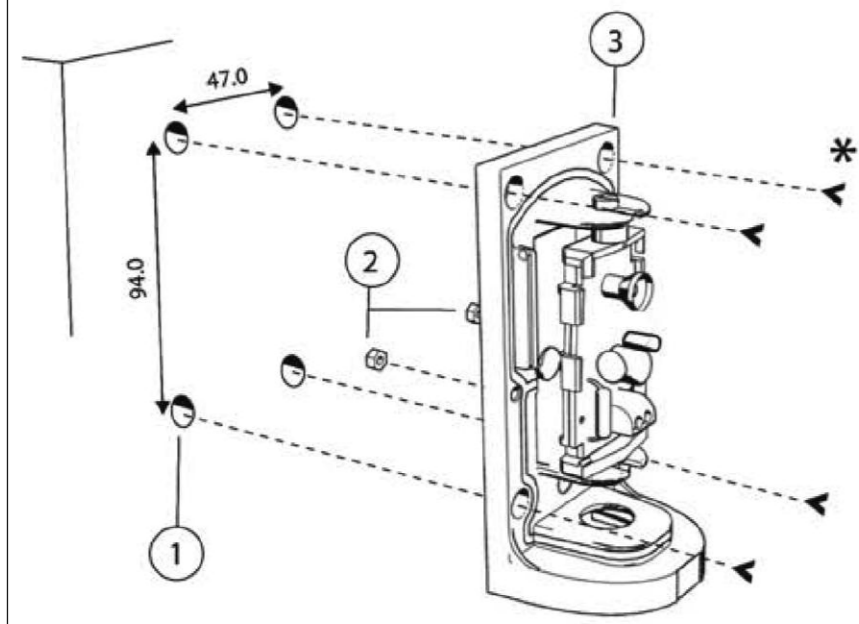
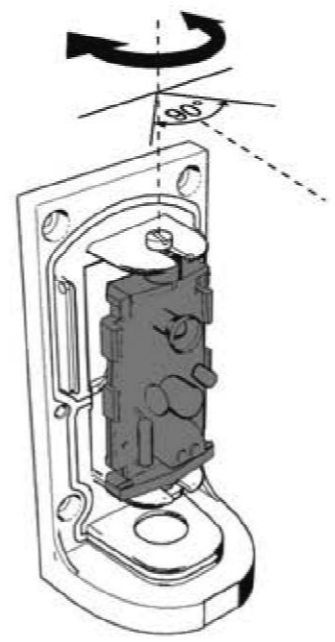

Closing the enclosure
Gehäuseabdeckung
Montaje de la carcasa
Chiusura contenitore
Fermeture boitier

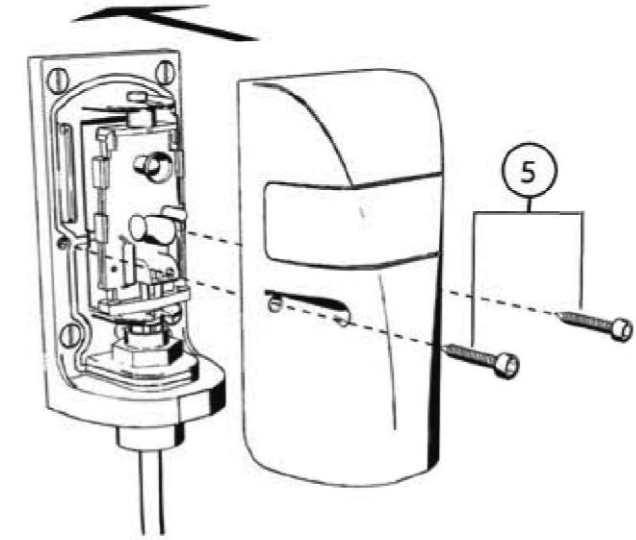

Connections
Anschlüsse
Conexiones
Connessioni
Connexions

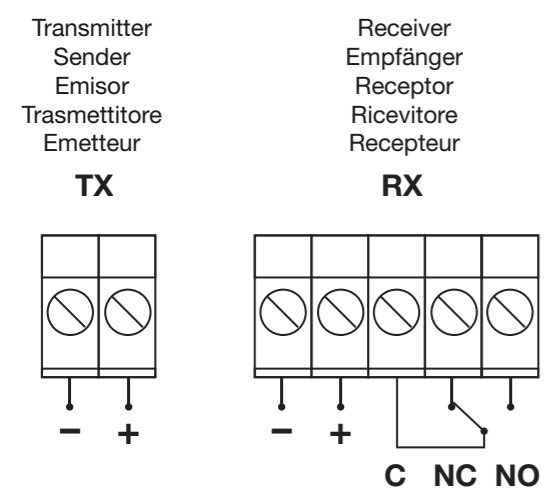

LED Power Signal
LED Signalisation Stromversorgung
LED Señalización Alimentación
LED Segnalazione Alimentazione
Voyant lumineux de Signalisation Alimentation

LED Alignment Signal
LED Signalisation Ausrichtung des Empfängers
LED de indicación del alineamiento
LED Segnalazione Allineamento
Voyant lumineux de Signalisation Aligneamento

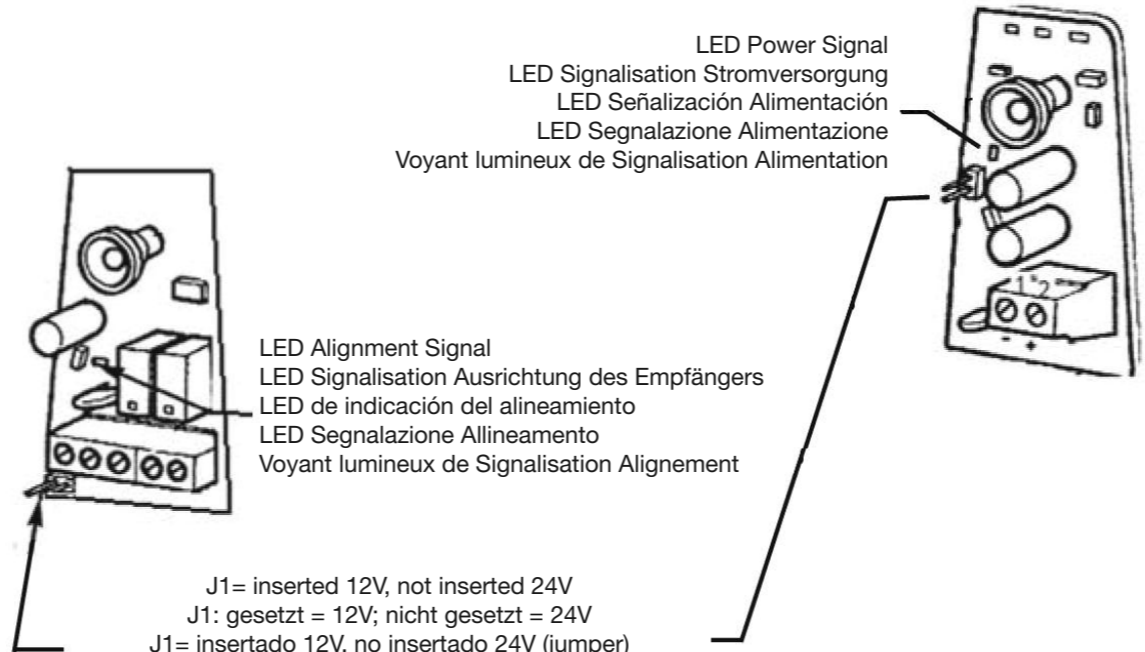

J1= inserted 12V, not inserted 24V
J1: gesetzt = 12V; nicht gesetzt = 24V
J1= insertado 12V, no insertado 24V (jumper)
J1= inserito 12V, non inserito 24V
J1= activé 12V, désactivé 24V

Overall Dimensions
Gehäusemaße
Dimensiones externas
Dimensioni d'ingombro
Dimensions d'encombrement

